

# Q-SPD

## Technical Specification

**New for 2012**  
**SD120-F**

### Dimensions:

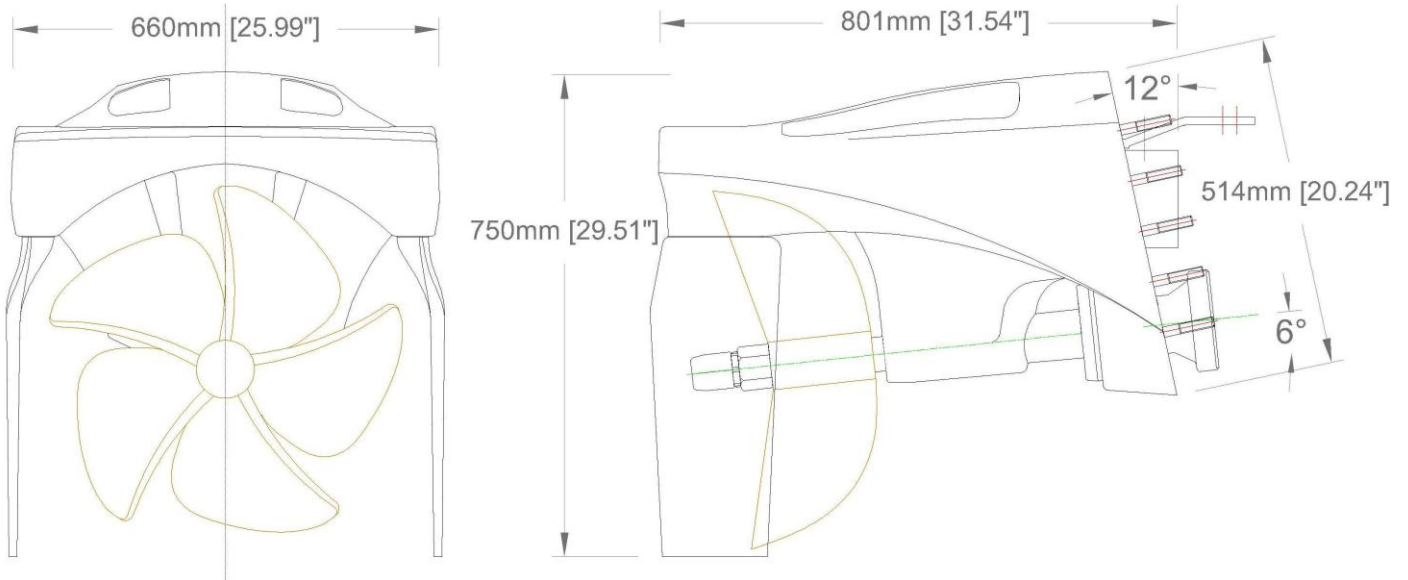

### Specification:

Model	SD120-F
Shaft Diameter	2.25" (57.2mm)
Max Propeller Diameter	24" (610mm)
Exhaust Diameter	6" (152mm)
Max Rudder Angle	35° + 35°
Steering Tiller Stroke	6" (152mm)
Max Thrust	15 kN
Max Torque	2,200 Nm*
Weight	90 kg (excl propeller)

### Materials:

Main Housing	Eglass/Epoxy Infused
Main Shaft	AS22 HS
Rudders and Tillers	Nibral
Thrust Housing and Coupling	Stainless Steel 316L
Fasteners	Stainless Steel 316
Thrust Bearing Type	QJ215
Water Lubed Shaft Bearing	Thordon XL
Main Shaft Seal	Single Water Lubricated Lip Seal

\* Pleasure/Light Duty application

\*\* Specification subject to change

### Options:

- Mechanical Tie Bar
- Intermediate Flexible Drive Shaft

**www.q-spd.com**

Designed and manufactured by:  
**Q-Marine International Ltd**  
Auckland, New Zealand  
email: sales@q-spd.com